

2024.11

LP-FS-PRO-3000

User's manual

OPTICAL FIBER FUSION SPLICER

USER'S MANUAL

Catalogue

Safety requirements	01
Warning/Precautions	02
Chapter I Machine Introduction	04
Component Introduction	05
Introduction to Key Combination	08
Introduction to Screen Interface	10
Explanation of fiber optic status prompt	14
Chapter II Machine Settings	16
Software Bluetooth connection	17
APP functions	22
Chapter III ARC calibration	24
Chapter IV Fiber Stripping And Put Into Holder	25
Chapter V Replace Electrode	27
Chapter VI Verification/activation of electrode	29
Chapter VII Cleaver setting	30
Delay return the blade setting	30
The using times of fiber cleaver cutting point blade cutting point change	31
Set the LED brightness of the cutter	33
Chapter VIII Replacing Blades	34
Chapter IX Adjust the blade height	37
Chapter X OPM and Optical Modules	38
Chapter XI Welcome Interface	40
Chapter XII Intelligent Management	41
Chapter XIII Daily Maintenance	43

At any stage of the operation of the fiber optic fusion splicer (hereinafter referred to as the "fusion splicer"), the following general safety measures must be taken. Failure to take these safety measures or comply with the warnings and precautions described in this manual will violate the safety standards for the design, manufacturing, and use of the welding machine. We do not assume any responsibility for the consequences caused by users violating these requirements!

● Operating environment and power supply

📌 Requirements for the working, storage environment, and working power supply of the welding machine

operation temperature: 0~+40℃ limiting temperature: -10℃~+50℃

Working humidity: below 95% RH (without condensation) maximum wind speed: 15m/s Storage conditions: -20℃~+60℃

Before connecting to the power supply, please ensure that the welding machine is provided with a matching power voltage and all safety measures have been taken.

- Do not use the welding machine in flammable and explosive environments
- Do not use the welding machine in the presence of combustible gases, smoke, or dust
- Do not disassemble or disassemble any components of the welding machine without authorization

Except for the parts that are allowed to be replaced by the user as stated in this manual, please do not disassemble any parts of the welding machine without authorization. Replacement of parts and internal adjustments can only be carried out by authorized maintenance personnel.

● AC/DC adapter

Voltage: 13.5V, output current 4.8A; Polarity: The center is positive. Using an adapter with inappropriate output voltage and current will cause damage to the welding machine or inability to charge. The input AC voltage of the AC/DC power adapter is 100~240V, 50/60Hz. If the input voltage exceeds this range, it will cause damage to the adapter!

● Internal lithium battery

The battery inside the machine is a dedicated lithium-ion battery, and using other batteries will damage the welding machine. For safety reasons, the lithium battery pack cannot be disassembled to prevent short circuits; Do not forcefully hit the battery; Do not approach or immerse the battery in sources of ignition and strong heat. Violation of the above operations may cause the lithium battery to explode, endangering the personal safety of the user.

▶ Note:

1. After being stored for a long time, the battery can easily enter a sleep state, and its capacity is lower than the normal value, resulting in a shorter usage time. However, it only needs to undergo 2-3 normal charging and discharging cycles to activate the battery and restore its normal capacity. Lithium batteries have almost no memory effect and can be charged at any time.
2. Lithium batteries have self discharge phenomenon, and batteries that have not been used for a long time will be in a low voltage state due to self discharge. Long term low voltage state can damage the internal structure of the battery and shorten its lifespan. Therefore, unused batteries should be charged at least once a month, and attention should be paid to charging up to the display of 2 or 3 cells, and should not be fully charged; In daily use, try to charge when the battery level shows more than one grid, and do not charge when the battery is depleted.
3. If the machine is not used for a long time, please remove the battery and store it separately. The temperature range for long-term storage of batteries (storage time exceeding 6 months) is: 0℃~40℃. The temperature range for short-term storage of batteries (storage time less than or equal to 6 months) is -20℃~60℃.
4. To ensure the safety of charging, the charging temperature range of the lithium battery inside the fusion splicer is 0℃~40℃.

● The use of fiber optic fusion splicer

When the welding opportunity encounters the following situations, please immediately turn off the welding machine and disconnect the adapter, battery, and welding machine. Otherwise, it may cause serious consequences such as the welding machine not working properly or unable to repair.

- ▶ Liquid and foreign objects enter the interior of the welding machine. There is a protective structure inside the machine, and a small amount of fiber optic debris falling into it will not affect its use. However, please try to be careful not to fall into it.
- ▶ The welding machine is subjected to strong vibrations and impacts.
- ▶ There are no components that require maintenance inside the welding machine, and disassembly of the welding machine is prohibited.
- ▶ During the electrode discharge process of the welding machine, the voltage between the two electrode rods can reach several dry volts. Do not touch the electrodes, otherwise it may cause serious consequences such as damage to the welding machine or even personal injury.

Note:

1. The welding machine is used for welding quartz glass fiber optic cables. Please do not use this instrument for other purposes. Please read this manual carefully before use.
 2. When using in dusty environments, try to keep the windshield of the welding machine closed as much as possible; Pay attention to cleaning the V-groove and lens during use (cleaning the V-groove can be done using an art knife along the fiber groove, and then using a brush to clean it); After use, the entire machine needs to be cleaned of dust.
- When the welding machine moves from a low temperature environment to a high temperature environment, try to adopt a gradual heating method, otherwise condensation will occur inside the instrument, which will have adverse effects on the instrument.
4. The welding machine is a calibrated precision instrument, please try to avoid strong vibrations and impacts. When storing, a dedicated carrying case should be used, and suitable buffered packaging boxes should be added outside the carrying case for long-distance transportation.

● LCD display screen

1. The LCD screen of the fusion splicer is not a touch screen. Sharp objects should not be used to click on the LCD screen, and it should not be forcefully impacted.
2. Do not drop organic solvents or dirt on the LCD screen, such as acetone, engine oil, antifreeze, ointment, etc., as this may cause abnormal display on the LCD screen.
3. The LCD screen can be cleaned by wiping with silk cloth or soft fabric.
4. The brightness of the LCD screen may vary depending on the viewing angle of the screen; There may be noise on the screen when the windproof cover of the welding machine is opened or when the optical fiber is not inserted. These are not malfunctions of the LCD screen, they are normal phenomena.

● Introduction to operating buttons and components

This machine is mainly used for connecting optical fibers, and can connect ordinary leather fiber optic cables, jumpers, and cladding diameters of $80\ \mu\text{m}$ - $150\ \mu\text{m}$. Multiple types of quartz based optical fibers such as single mode, multimode, and dispersion shift for m. During use, attention should be paid to maintaining cleanliness and avoiding strong vibrations or impacts.



OPM VFL power switch: ① - ⑤ Cycle: ①. Turn on light work, wavelength 1310. ② Switch wavelength 1550. ③ Switch wavelength to 850. ④ Turn on the red light. ⑤ Turn off light power and red light.

Blade rotation button
Short press: Display the current blade cutting point number
Long press for 3 seconds: The blade cutting point will automatically rotates and change one point

Reset key: Press the reset key to reset the propulsion motor, core adjustment motor, and focus motor to the original point. The reset key light will turn on to indicate that the reset is in progress, and it will automatically turn off within 5 seconds to indicate successful reset. Otherwise, the reset will fail.

Continue key: has three functions
① Forced fusion: In the case of poor fiber cut surface or fiber recognition error, the machine will not automatically fuse. Press this key to ignore errors and force welding.
② Secondary welding: After the welding is completed, within 15 seconds (without opening the wind cover), press this button once to discharge the welding machine again for supplementary welding. This function can improve the defects of the fusion joint after the first fusion. For example, welding defects caused by insufficient firepower and insufficient cleaning of the cutting surface.
Note: This function is only used to assist in welding. If welding defects often occur, the cutting tool should be checked or discharge correction should be redone.
③ Step by step fusion function: You need to first activate the "Fusion Process Pause" function (Fusion Settings - Function Settings) on the mobile phone's "Signalfire2". When the left and right optical fibers align with the screen, they will not automatically fuse. You need to press this button to complete the fusion process.

Zoom in key: Switch between displaying images at 200x and 300x.

Machine power switch: Long press to turn on or off the machine.

Optical power input and red light source output interface

Tool clamp box

Component Introduction

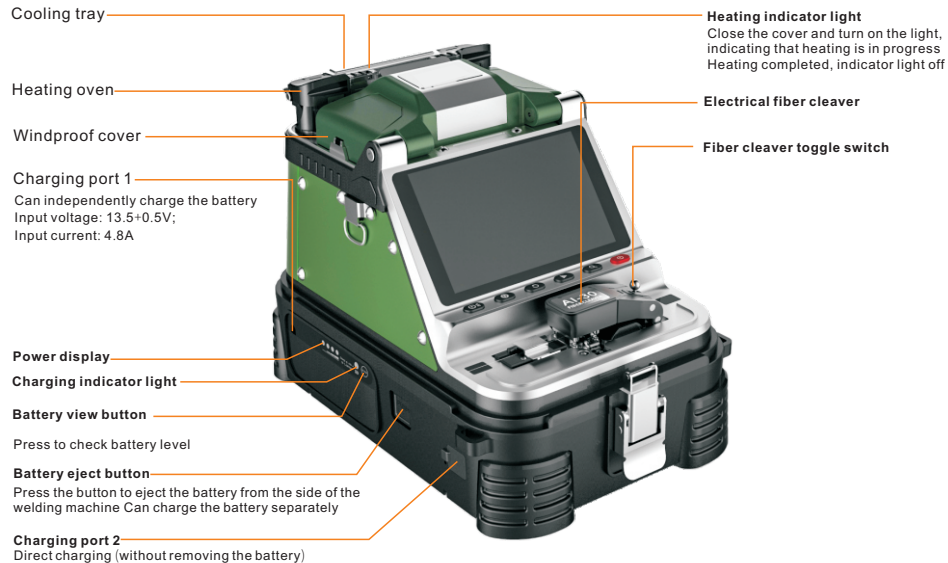

Component Introduction



Component Introduction

Schematic diagram of work combination



Introduction to Key Combination

The four function keys at the bottom of the screen, except the basic functions which has been introduced above, there are also some combined functions for daily maintenance of the machine.

1.force upgrade mode: in the shutdown state, press and hold the reset key(the left first one) and the power button, and the machine enters the force upgrade mode.

Usage :In this mode, connect the phone again-Signalfire2,firmware updates are more stable, faster, and can force a firmware refresh.When normal upgrades fail, it's easier to succeed with this feature.

2.Self-check of optical fiber fusion splicer: in the shutdown state, press and hold the continue button(the left second one) and the power button at the same time, and the machine enters the self-check mode.

Usage: When the welding machine is not working normally and the hardware is suspected under problem, it can be confirmed by machine self-checking. For example, fiber align procession is normal, but there is no welding arc, you can check whether the "HV-Discharge" is error.

After entering the self-check, the test time will be displayed at the bottom of the screen. When all the 12 firmwares are self-checked over, if the firmware is under problem then the red font will be displayed, that means the correspond firmware has problem may need to replace it. please contact the after-sales service to deal with it.

The meaning of the 12 self-checking items as following

01 Image processing	Image processing	Report an error,please check again. If the error is still reported, please contact after-sales service
02 Data Rom	Data Rom	
03 Data Ram	Data Ram	
04 Controller	Controller	report an error,Please contact the after-sales service
05 Motor: PL PR AL AR	Fiber control motor: Push motors and align motors each one pair	
06 Focusing Motor: X Y	Focusing motors :2	report an error, first clean up the lens, upgrade the firmware.If the fault persists, Please contact the after-sales service.
07 Camera: X Y	One pair	

Introduction to Key Combination

08 Camera LED: X Y	Camera LED:two	report an error,Please check whether the red light above the electrode is bright and dim(see electrode replacement for specific operations)If the fault persists,Please contact the after-sales service.
09 RTC	RTC	Report an error,please check again. If the error is still reported, please contact after-sales service.
10 Battery	battery	unplug the battery and plug the battery again, check whether the battery plug into the machine firmly.check the battery socket is there any rust. if the problem is still there, please contact after-sales service.
11 HV-Discharge	HV-Discharge	check the electrode mount good or not, check the discharge wire connection to the electrode base is that well. if that's all good and the "HV-Discharge" error shows in the self-checking result, please contact after-sales service.
12 Bluetooth	Bluetooth	If error reported, please contact after-sales service.

OPM & VFL Introduce

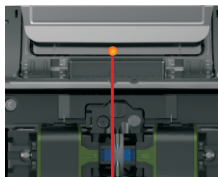

Preheating
when the fiber fusion succeed then open the wind cover, the heating oven will turn on this light and preheat the oven 6s

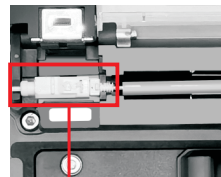

Heating part compatible with SC fiber
SC Fiber: Push up
Ordinary fiber: Push down

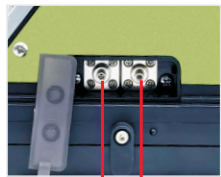

OPM
VFL

Introduction to Screen Interface

ICON	NAME	FUNCTION
	Normal mode	Normal Splicing Mode For The Machine
	Splicing process pause	When the function is on,the splicing machine will stop the final splicing process after the fiber has aligned. Then press the "▶" button to finish the fiber fusion. when you meet the fiber end face is not good and angle exceed the upper limit value, it will pause and report the error. Press the "▶"key to ignore the error and continue to fiber fusion process.
	Auto focus	When the function is turned on, for each time splicing it will adjust the camera focal length to the set target value automatically. we recommend turn off the function cause it will slow down the fiber fusion speed.
	ARC calibration	According to the altitude, temperature, humidity and other conditions of the user, match the most suitable arc discharge value to minimize the splicing loss.(See chapter 4, discharge correction)
	Turn on the Smart lock	managers or owners can effectively manage the use period or times of fusion splicer. Typical application scenarios include: fiber fusion splicer rental business
	Continue button	Press the "Continue" button to continue the splicing process

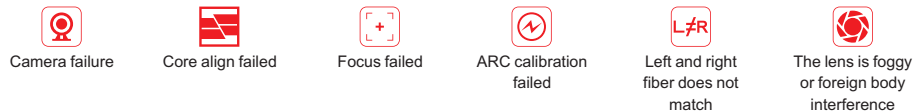
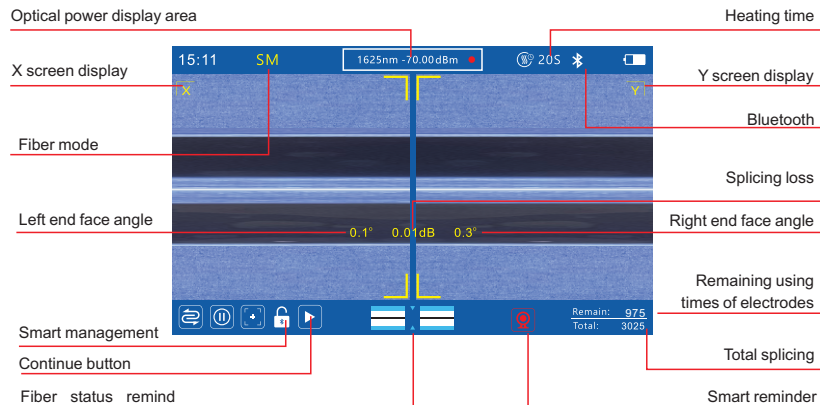

Intelligent prompt and fiber state prompt solution

I Intelligent prompt

The red icon which shows in the left bottom of the LCD Screen.

- **Camera fault** : first clean the objective lens, If the fault still exists, please do a machine self-checking of the splicer to confirm whether the camera fails (please refer to daily maintenance for specific operation).
- **Align failure** : check the fiber cleaved is that in good condition, such as the coating layer is not clean, too bad cutting surface, too many burrs; Then clean the V-grooves with knife, clean the outside lens which below the electrode and press the reset key. Note: dust in the lens may also cause failure of core alignment, so dust should be cleaned (this please contact after sales service).
- **Focus failure** : only happened when autofocus function is turned on, usually shows the fiber image is too blurry. Solution: check the fiber cleaved is that in good condition, clean the V grooves and outside lens, press the reset key; turn off the autofocus function manually (see daily maintenance for details). If the fault continues, do a machine self-checking to check whether "focusing motor" error. Note: dust in the lens may also cause failure of core alignment, so dust should be cleaned (this please contact after sales service).
- **Arc Discharge failure** : First clean the tip of the electrode and remove debris; Restore the factory Settings from App "Signalfire2". Restart fiber splicer, Then do the arc calibration. If the fault still have, do a machine self-checking to check whether "HV-Discharge" error.
- **The left and right optical fibers do not match** : the specifications or types of optical fibers on both sides are different, and they need to be replaced with the same specifications or types. This error, can press continue to ignore the key error then force to do fiber fusion. **attention:** according to the construction specifications of fiber splicer, different specifications and types of fiber cannot be fused, if forced splicing, fusion quality may be affected.
- **Fog or foreign matter on the lens** : check the fiber cleaved is that in good condition and cleaned no dirt on it, and then clean the outside lens; In addition, if the red light failed which in on the electrode, it also will report this. (checking method: Open the electrode cover, and the lights is light up. If not, it is broken and needs to be replaced).

Explanation of fiber optic status prompt

- **Electrode replacement warning**  : When electrode splicing times reaches 3800, warning icon will appear, reminding you to prepare a new electrode and be ready to change it.

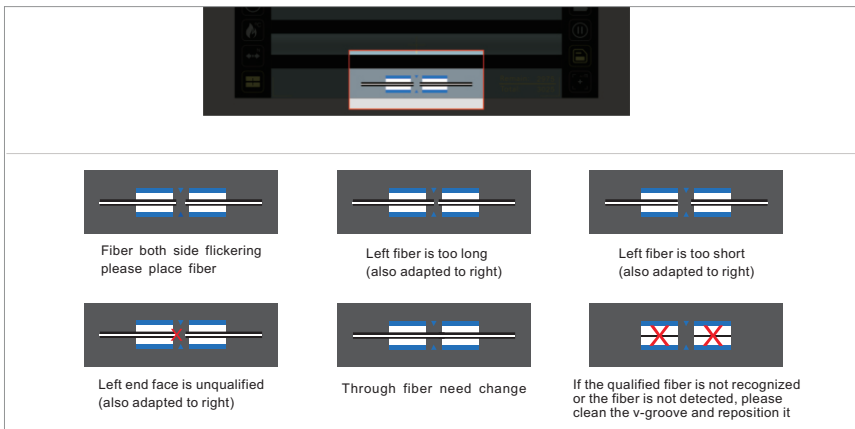

Fiber status prompt description

Explanation of fiber optic status prompt

II Fiber state prompt

there is an icon shows the fibers on the V-grooves status in the middle of the LCD Screen bottom: white and blue square means the V-grooves. Black and white long line means optical fiber. Triangle means the electrode tips. above pictures are what we have show you about the different status of the fiber on the V-grooves. Attention: fiber end face please put close to the electrode tips but not exceed tips.

● Put the optical fiber on V-grooves

when you open the wind cover and both side fiber icon flickering, that means we need to put the cleaved fiber on the machine V-grooves. when you close the cover, then the icon will change and then a few seconds it will tell you the fiber status as what we show you the pictures above. when you open the wind cover the page still the boot display page, and even you try many times to open and close the cover, the machine doesn't beep and the page doesn't change, then the machine's sensor happened problem. need to check the splicer wind cover left side magnet's magnetism and the correspond position Allen screws on the panel did they are tighten.

● Fiber put too long on V-grooves

if the icon show you that one side fiber flickering and the end face reach the triangle position, that means the fiber put too long. we need replace the fiber again until the icon no remind again. if you have checked that the fiber is not exceed the electrode tips, but icon also remind you that fiber put too long, then we need to clean the outside lens which under the electrode. if the lens have fog then we use hair dryer to dry it. if you have done above steps and still give you the remind of the fiber too long, please contact after sales service.

● Fiber put too short on V-grooves

the icon show you that fiber end face is in the V-groove and not exceed it, that means the fiber put too short and is not close to the electrode tips. we need put the fiber again and make the fiber end face close to the electrode tips and not exceed the tips. normally the jump fiber may happen this problem because the sleeve will slide and make the fiber not move then the icon remind you this situation. if you meet this problem, please contact our after sales service.

- **The end face is not acceptable**



fiber end face there is a red "X", that means the fiber end face is not acceptable, then we need re-cleave the optical fiber until cleave the fiber have a good end face. if you have try many times and each time show you that the end face is bad, then we need check the cleaver is that we need to adjust it. if the cleave end face is good, but when the pre-discharge make the fiber end face round and the icon remind you, then we need to do an arc calibration to make the pre-discharge lower so that the machine will be back to normal work again. if the machine show the fiber blur, will also make the error icon, and about the fiber display blur, please check daily maintain.

- **The test is fiber passing**



Fiber passing means screen display is a complete fiber, take out fiber can be normal. Sometimes errors may be reported due to dirty lens or fog, and the lens can be restored after cleaning (see daily maintenance for specific operations).

- **Failed to recognize fiber or failed to detect fiber**



V-grooves icon there is a red "X", that means machine didn't recognize the fiber or the fiber didn't put on the V-grooves. if the optical fiber has put on the V-grooves and the error icon still have, check the fiber has been cleaned and cleaved, then clean the outside lens and the V-grooves, press the reset button(the left first one), if the display shows the fiber is blur, also will make the error icon happen. these you can check in the daily maintain chapter.

Software download

China: scan QR code to download APP

Outside China: Go to Google Play or App Store and search for"Signalfire2 "download Phone App.



Google play



App store



Scan QR code

Software Bluetooth Connection

Mobile APP is used for the function setting, fiber fusion record storage, account binding, firmware upgrade. when you use the machine normally, we don't need to connect the mobile app to machine.

Phone settings

1. Apple phone(IOS system) to turn on bluetooth permissions.

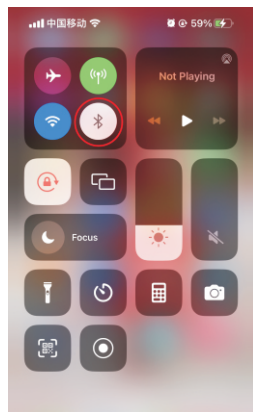

1 Turn on the iPhone system Bluetooth function.

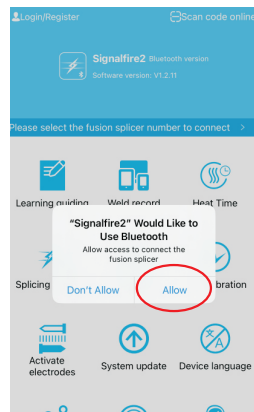

2 Allow the Bluetooth permissions

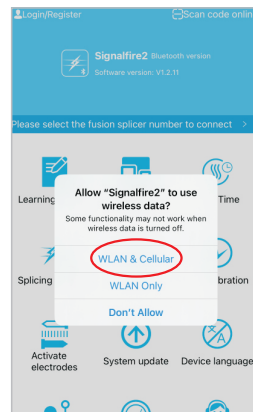

3 Allow the WLAN&Cellular permissions

Software Bluetooth Connection

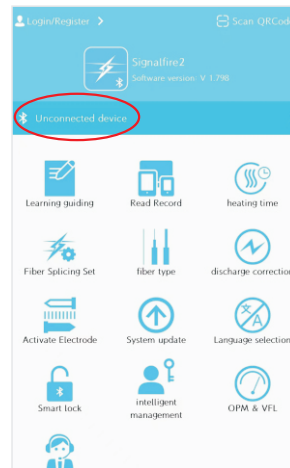

4 Press the "Unconnected device" to search the machine SN

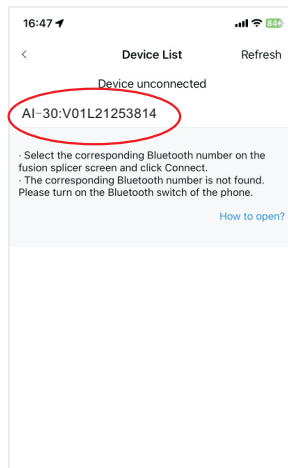

5 Press the machine SN to connect the machine.

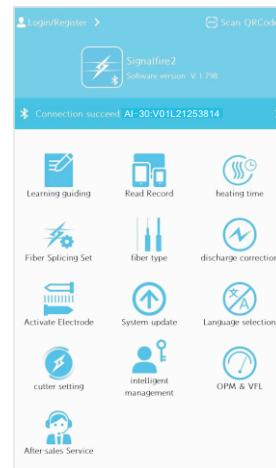

6 Remind you succeed then turn into the main page.

Software Bluetooth Connection

2. Android phone to open the bluetooth permission function is as follows

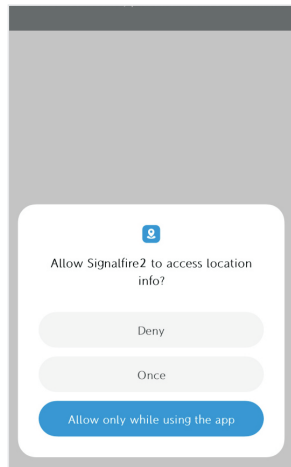

1 Allow the Phone location permissions

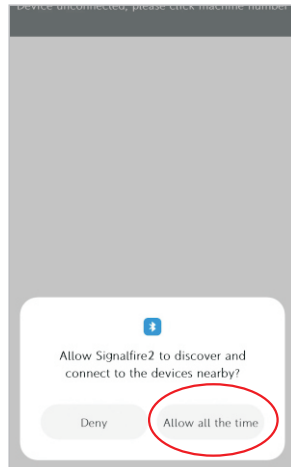

2 Allow the device finding

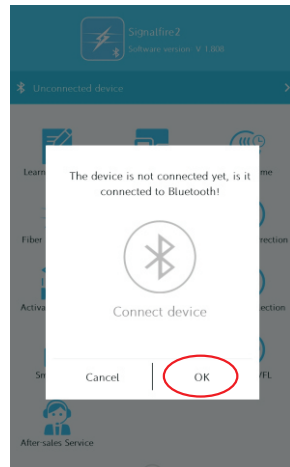

3 Allow the Bluetooth permissions

Software Bluetooth Connection

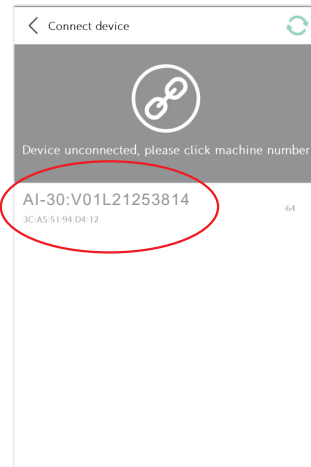

4 Press the machine SN to connect the machine.

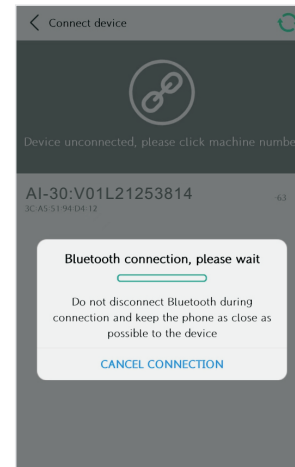

5 Connecting

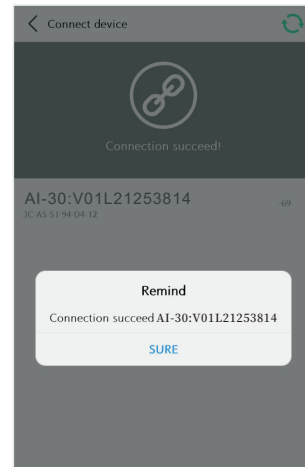

6 Connection succeed

Software Bluetooth Connection

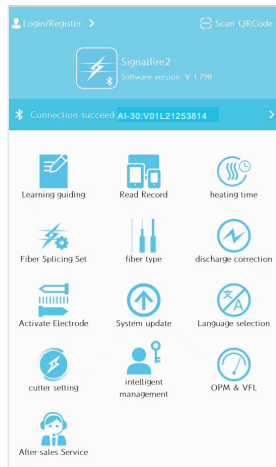

after you connect the machine to the mobile APP, then we can have a setting of the machine function, each function means one icon which shows on the LCD Screen. these function after you have set them and save the setting, you can use it as what you have set without app connection in the future.

7 Back to the APP main page

APP function

Enable mobile Bluetooth, connect to the welding machine, run the APP, set and debug the functions of the welding machine, export welding data, upload cloud storage, firmware upgrade, and account binding, and achieve intelligent management and other interconnection functions

Parameter settings

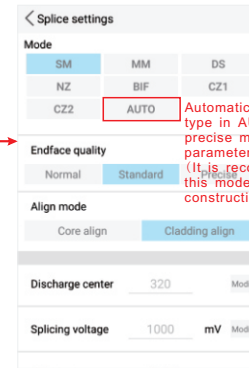
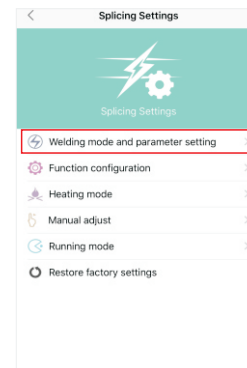
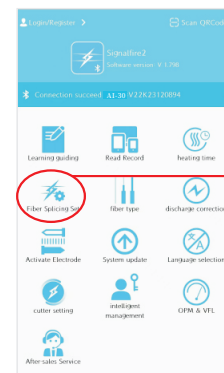

Automatic identification of fiber type in AUTO mode and precise matching of connection parameters for core fusion (It is recommended to choose this mode for mainline construction)

Exit the page after making changes and automatically save it

Function configuration: slider on or off function

The screenshot shows the 'Splicing Settings' app. The 'Function configuration' option is highlighted with a red box. An arrow points to a detailed view of the 'Function configuration' screen. In this view, several settings are highlighted with red boxes and accompanied by explanatory text:

- Cleave angle detection:** Slide the slider right (on) and left (off) to exit the page and save it automatically.
- Splice process pause:** Step by step fusion (default off). After opening and pre pushing the fiber, press to continue key can be used for the subsequent fusion process.
- Auto focus:** Default off, faster fusion speed (enable to improve fiber recognition rate).
- Power off after standby:** Set to timed automatic shutdown without any operation.

ARC Calibration: According to the local ground elevation, temperature, moderate and other environmental factors to match the most suitable discharge ARC, in order to obtain the best splicing effect, we strongly recommend you to do arc calibration when it is the first time to use the new machine, the seasonal changes, the use place changes, or you replaced the electrodes; discharge correction should be done after changing the type of fiber (such as single mode and multi-mode switching)

The procedure for ARC Calibration is as follows:

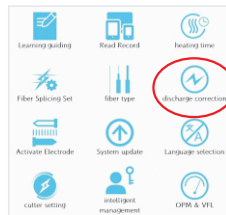

- ① log into your account;
- ② connect the machine to APP;
- ③ press the "arc calibration" button

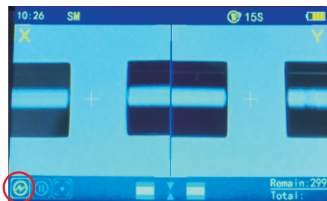

Machine fusion page on the left side, there is a normal work status icon will change into the arc calibration status icon. And then you can put the cleaved fiber on the machine, and close the wind cover, wait the machine automatic to process the arc calibration.

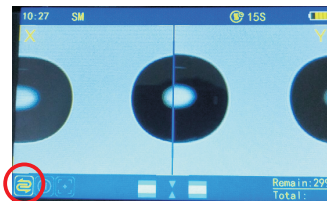

If the icon still the icon of the arc calibration, but the fiber icon is flickering, we need to take the fiber out of the machine. then cleave a new fiber again and put it on the machine and wait the machine process. loop above operation until the icon change from arc calibration icon into normal working icon which means the arc calibration succeed.



How to cleave the fiber?

1. Press the cleaver clamp and then toggle the cleaver switch to the right to unlock the cutter.
2. Place the fiber on the fiber holder.
3. Manually press the cleaver clamp to cleave the fiber.

How to change the blade?

The cleaver is set to 24 blade cleaving point. When one of the positions cannot be used normally, press and hold the "blade rotation" button for  3 seconds, and the blade automatically rotates to next one point. (Short press the "blade rotation" button to view the number of times of current point has been used).

Instructions for put fiber into holder:

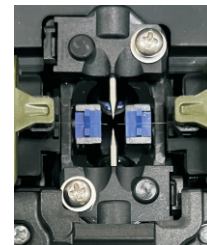
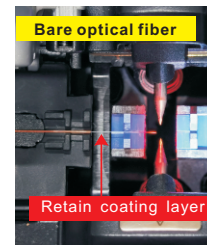
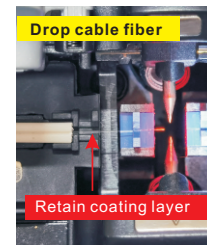
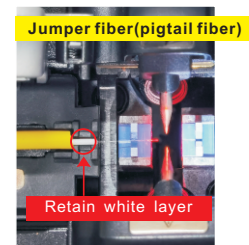

- Note: 1. When releasing the fiber, pay attention to placing the fiber in the blue V-shaped groove. The top of the fiber should be close to the needle tip of the electrode. If it is too far from the electrode needle tip, it will prompt to re release the fiber.
2. The top of the optical fiber should not exceed the tip of the electrode needle

Chapter V Replace Electrode

When replacing the electrode, you must use official electrode which come with QR code for this machine. The service life of the electrode is 4000 times.

When the electrode splicing times reaches 3500, the machine screen will display a prompt "To ensure the splicing quality, please prepare to replace the electrode";

when the electrode splicing times reaches 3800, the machine screen will display a prompt "The electrode life is about to expire, please replace the official electrode and verify the QR code ⚠️";

when the electrode splicing times reaches 4000, please replace the new electrode and verify the electrode code in APP (verification/activation of electrode see page 30).

The electrode replacement procedure is as follows:



1. Loosen the two lampshade screws 1 and 2 and remove the lampshade.



2. Loosen the two electrode cover screws 3 and 4 and remove the two electrode covers.

Note: One side of the electrode cover is a latch structure, so it needs to be removed diagonally.

Replace Electrode

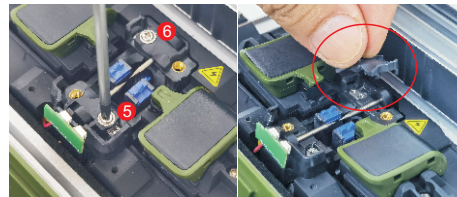

3. Loosen the two electrode fixing screws 5 and 6 and remove the fixings



4. Replace the new electrode (electrode number: ZS-750), Install in reverse order, and the electrode replacement is completed.

Note:

1. The screws only need to be screwed in place and fixed, and do not need to be tightened too much to avoid damage to the hole.
2. Enter the mobile phone APP-Signalfire2, scan or enter the electrode code on the electrode box for verification and activation.

Chapter VI Verification/activation of electrode

The official code verification is operated by the mobile phone APP "Signalfire2". Please scan the QR code on the machine screen or get in APP Store to download the software before use.

ATTENTION: after you have replace the electrode and verify the code, please remember to do an arc calibration so that the machine can performance better. the method to verify the electrode:

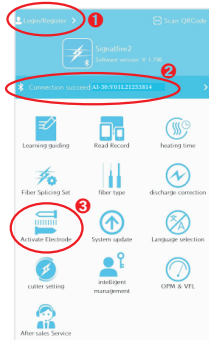

- 1 log into your account;
- 2 Use APP to connect to the machine
- 3 press the button "Activate Electrode", then get into the page of the electrode activation

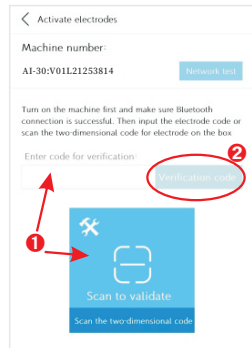

- 1 Scan the QR Code which is on the electrode cover, or you can input the QR Code Number into the text box.
- 2 After the number is show in the text box, then we press the button "verification code" to activate the machine.

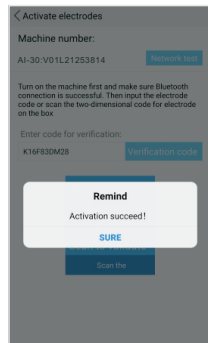

After you have done the verify the code, then it may load for few seconds, then it will remind you "Activation Succeed". then the machine can normal use again.

Chapter VII Cleaver setting

1.Delay return the blade setting

This machine comes with a high-precision delay return one-step optical fiber cleaver, which is a perfect high-quality fiber cleaver, perfectly solving the problem of traditional mechanical one-step fiber cleaver scratching the fiber end face.

The factory standard setting of the delayed return is 0.5 seconds, which can be changed. The setting range is 0. 2-2 seconds.

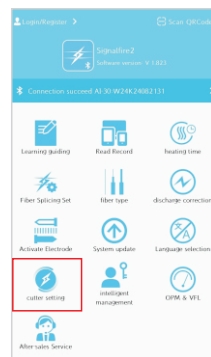

1.Turn on the fiber splicer, open the cleaver, and then connect the welding machine APP.

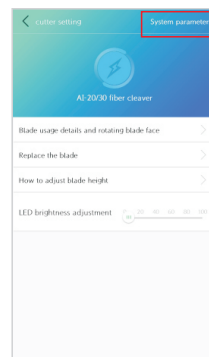

2. Click "system parameters" button

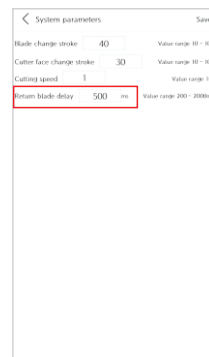

3. Modify the "return delay" parameters

2.The using times of fiber cleaver cutting point | blade cutting point change

View in the mobile phone APP

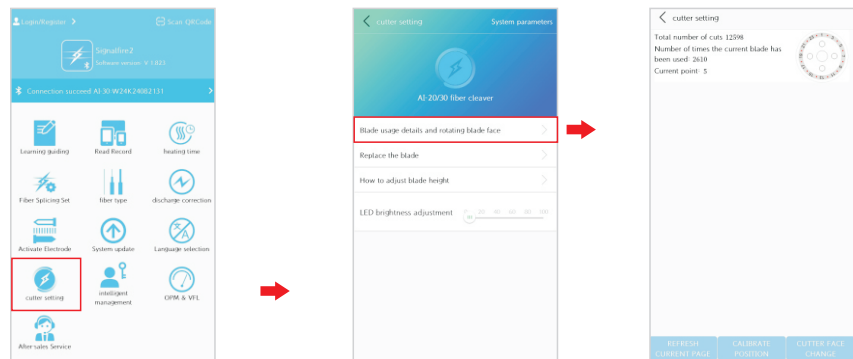

1.Turn on the fiber splicer, open the cleaver clamp, and then connect the welding machine APP.

2.Click "blade usage details and rotate the blade surface" button

3. You can view the "total number of cuts" and the blade cutting point "current position".

Press the Splicer "cleaver buttons" to view the blade points and change the blade cutting point

The cutter is set to 24 blade cutting points. When one of the points cannot be used normally, the point needs to be replaced.



Short press: Display the current blade cutting point number.

Long press for 3 seconds: The blade cutting point will automatically rotates and change one point



The cutter is set to 24 blade cutting points

3. Set the LED brightness of the cutter



1. Turn on the fiber splicer, open the cleaver clamp, and then connect the welding machine APP.

2. Drag the slider to change the brightness.

When the cutting quality cannot meet the cutting requirements, please replace the blade in time. When replacing the cutting blade, you must use a regular original blade designed for this machine, otherwise it may affect the installation and the cutting quality cannot be guaranteed.

Tip: You can use the APP to check how to change the blade, adjust the blade height, blade usage, etc.

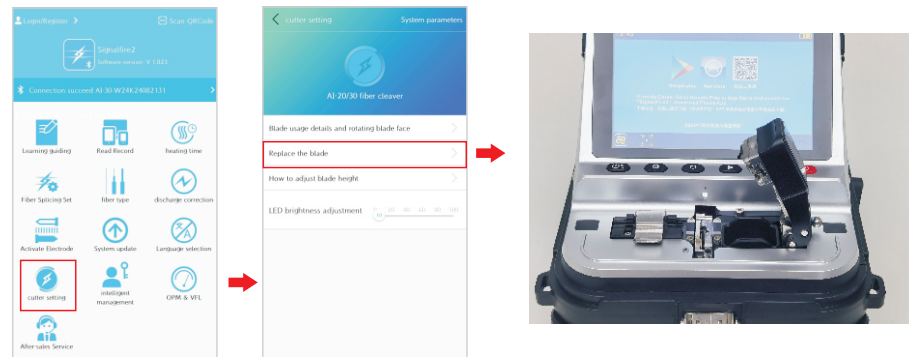

1. Turn on the fiber splicer, open the cleaver clamp, and then connect the welding machine APP.

2. Click to switch to the "blade change mode".

3. Please open the cleaver cover, press the power button to turn off the fiber splicer.

Replacing Blades

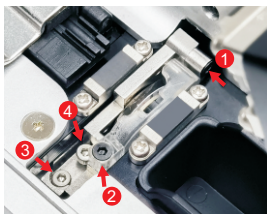

4. Number of screws to be removed

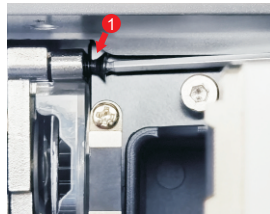

5. Use an M1.5 Allen wrench to unscrew "Screw 1" counterclockwise.

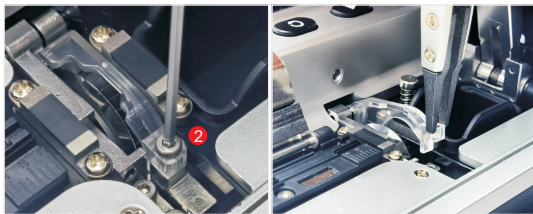

6. Use an M1.5 Allen wrench to unscrew "Screw 2" and then remove the "Blade Cover".

Replacing Blades



7. Use an M1.5 Allen wrench to unscrew "Screw 3" and then remove the blade holder upwards.



9. Confirm that the "cutting point number 1" of the new blade assembly is facing upwards, as shown in the figure. If not, use a cotton swab to rotate the blade so that number 1 is facing upwards (if the cutting point numbers do not match after installation, you can enter the "Blade Usage Details and Rotating Blade Surface" of the "Cutter Settings" of the APP to "Correct the Point").



8. Use an M1.5 Allen wrench to remove "Screw 4", which needs to be installed on the new blade assembly later.

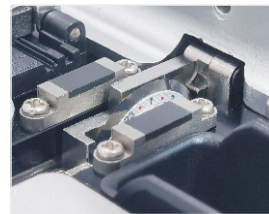

10. Put the blade assembly back on the blade holder, screw on the fixing screws and cover in turn, **and then the blade height must be recalibrated. Please refer to "How to Adjust the Blade Height" (next page).**

Chapter IX Adjust the blade height

When replacing a new blade assembly or using the fiber cleaver, the cutting quality may not be ideal due to the change in blade height, and the blade height needs to be adjusted.

The following is the method for adjusting the blade height: the tool is an M1.5 Allen wrench.

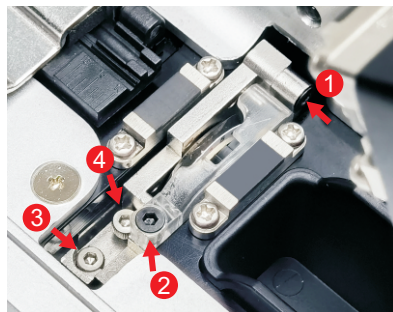

Raising the blade holder:

1. Loosen the blade holder shaft screw 1 counterclockwise.
2. Loosen the adjustment screw 3 counterclockwise, then turn the adjustment screw 4 clockwise to raise the blade holder.
3. Tighten the adjustment screw 3 and the shaft screw 1 clockwise and try cutting.

Lower the blade holder:

1. Loosen the knife holder shaft screw 1 counterclockwise.
2. Loosen the adjustment screw 4 counterclockwise, rotate the adjustment screw 3 clockwise, and lower the knife holder.
3. Tighten screw 1 clockwise and try to cleave the fiber.

If the trial cleaving does not meet the requirements, please repeat the above operation.

Preliminary adjustment of the knife holder height: The current cutting point (highest point) of the blade is flush with the fiber pressing plates on both sides, and then try cutting, and make fine adjustments according to the fiber end face image.

Judgment of blade holder height adjustment:

1. Unable to cut or sharp thorns on the edge of the end face, the blade holder needs to be raised;
2. The end face angle is too large, the end face or fiber core is defective, and the knife holder needs to be lowered;

When adjusting each time, the screw does not need to be rotated greatly. It is recommended to rotate 90° each time for fine adjustment.

Chapter X OPM and Optical Modules

Effectively measure connection loss, verify continuity, and assist in evaluating the transmission quality of fiber optic links. If you need to set parameters, please download the "Signalfire2" app to set it.

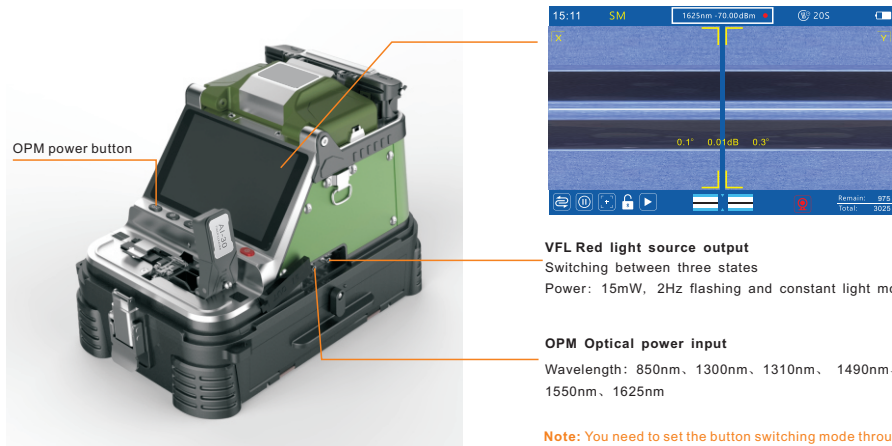

OPM power button

VFL Red light source output

Switching between three states

Power: 15mW, 2Hz flashing and constant light mode

OPM Optical power input

Wavelength: 850nm、1300nm、1310nm、1490nm、1550nm、1625nm

Note: You need to set the button switching mode through the APP

Optical power parameter settings

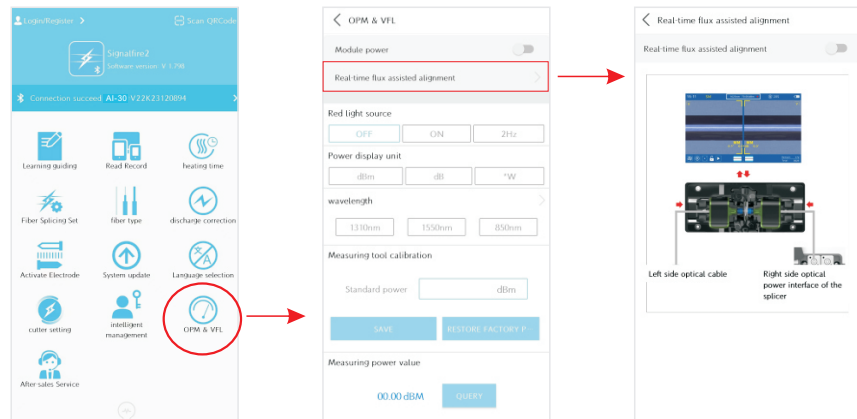

1. The user logs in to the "signalfire2" app and connects to the machine Bluetooth.

2. Turn on the OPM& VFL module, set and return.

New machine startup welcome interface: When a newly purchased fusion splicer starts up, the welcome interface will be displayed. After the user completes the fusion splicing of a single fiber, it will not be displayed again.



Intelligent management: Intelligent management is used to set the working hours and usage objects of the welding machine, making it convenient for administrators to effectively manage their own devices.

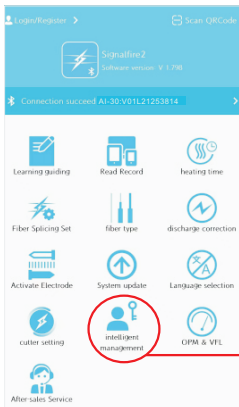

1. Bluetooth connection between mobile phone and welding machine

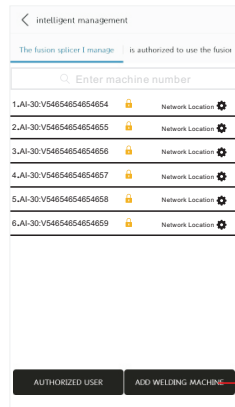

2. Click on Intelligent Management to view and manage your own welding machine.

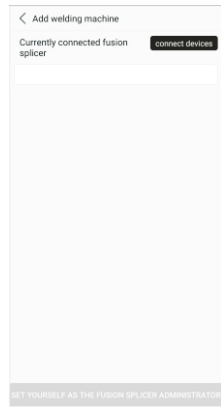

3. Click on Add Welding Machine to add the welding machine to be managed.

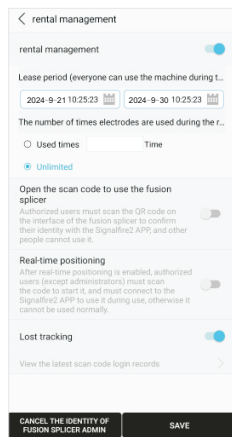

4. Click on the setting icon “⚙️” to personalize the welding machine.

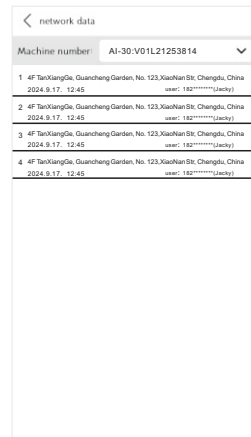

5. Click on the network location to view the addresses used by the welding machine online.



6. If you are authorized to use a welding machine, you can view the welding machines that you have been allowed to use by other welding machine administrators.

I .Pay attention to dustproof and remove dust

V-grooves, electrodes and Lens must be kept clean usually and windshield cover should be closed if you don't use it.

1. V-groove Cleaning

If the V-groove has dirty, then the fiber can not align and dislocation and give you an error message. Thus in the daily work, you should always check the V-groove and regular cleaning V-groove.

the method to clean V-grooves:

- 1)use the utility knife to scratch the V-grooves one direction, and make for about 3 times.both side need to clean like this.
- 2)use alcohol swab to clean the V-grooves again.

2. Cleaning the electrode

If the electrode is dirty or the electrode tips become dark, you need to clean the electrode:

- 1) use the knife to scrape the tip's dirt and keep it clean.
- 2)use alcohol swab to clean the tips.

3. If the outside lens which is under electrode is dirty, the fiber may be blur then give you an error message,or the fiber can be spliced but it will give you a high loss fusion.

Follow the steps below to clean the lens :

- (1) make sure that the machine is turn off.
- (2) Use alcohol swab to gently wipe the lens. Then wipe with a dry cotton swab to remove extra alcohol.
- (3) Turn on the power, make sure that the display is not visible dust and stripes.

II . Prevent Strong Shock or Vibration

When you need to move or transport the fusion splicer, please be careful and gently. For long-distance transportation, please wrap it with foam to prevent collision

III. Storage

When you do not use the machine for a long time, please must turn on the machine once half a year. if in high moisture environment, please use the machine often and put the desiccant into the carry case to prevent mildew microscope head.

IV.Precautions

- (1)When the fusion splicer is using AC power , please take attention to protect the adapter , and the power supply is properly grounded.
- (2)When the fusion splicer is in the ARC discharge process, there are several kV high voltage between the electrodes, please do not touch the electrode rod at this time!
- (3)Please be sure that there is no gasoline, biogas, Freon gas and other flammable gas in the environment to avoid the poor fusion or accident.
- (4)When you wipe to clean the fiber holder and lens, please must use cotton swab to wipe in one direction.
- (5)There are many structural precision components in the fusion splicer.Except the electrodes, the other part is banned for user to disassemble and change. Because these parts' position are precision-calibration, once there is any changes, it is difficult to return to its original position.
- (6) The objective lens, V-groove, display screen, etc should be kept clean. Clean only with cotton swab or alcohol swab, you can not use other chemicals.

V. Troubleshooting and solutions The table lists a general troubleshooting method for the user reference. When the user can not solve the situation, please contact with the suppliers directly.

Troubleshooting	Reason	Solutions
No image after placing fiber	<ol style="list-style-type: none"> 1. Not power on 2. Fiber isn't in V-groove or v-groove has dirt 3. Fiber put too short on V-grooves or fiber is broken 4. The align mechanism is not initialized 5. No signal detected for close windshield cover 	<ol style="list-style-type: none"> 1. Press the power key 2. Re-place the fiber or clean the V-groove 3. Re-cleave the fiber 4. Press RESET key 5. Check if the magnet on wind cover left side is fall off or the correspond position Allen screw on the panel is loosen.
splicing loss is too high	<ol style="list-style-type: none"> 1. The cleaving quality of the fiber is poor 2. Splice parameters unreasonable 3. discharge center offset (rarely occurs) 	<ol style="list-style-type: none"> 1. Re-cleave the fiber 2. Repeat the ARC calibration 3. Repeat the ARC calibration
The ARC does not discharge or has scars	<ol style="list-style-type: none"> 1. The cleaving quality of the fiber is poor 2. The splice parameter is too small 3. The electrodes has adsorbed dust 4. Running data error 	<ol style="list-style-type: none"> 1. Re-cleave the fiber face 2. increase the cleaning voltage; do ARC calibration again 3. Clean the electrode with a brush 4. Turn off and restart.
The spliced area becomes thinner	<ol style="list-style-type: none"> 1. Splicing parameters unreasonable, splice voltage is too high 2. Splicing overlap is too small 	<ol style="list-style-type: none"> 1. ARC calibration 2. Increase the amount of splicing overlap
splicing zone is thicker	<ol style="list-style-type: none"> 1. Splice parameters unreasonable, splice voltage is too small 2. Splicing overlap is too big 	<ol style="list-style-type: none"> 1. ARC calibration 2. Reduce the amount of splicing overlap
Splicing has bubbles (usually occurred in the multi-mode fiber splice)	<ol style="list-style-type: none"> 1. Fiber end with burr, not flat 2. Fiber quality is not good 	<ol style="list-style-type: none"> 1. Increase the cleaning voltage 2. Re-cleave fiber 3. Replace to qualified fiber or cut off a part of the existing fiber and try again.

Troubleshooting	Reason	Solutions
Splicing points have vertical shadow line	<ol style="list-style-type: none"> 1. Fiber core does not match (type or core diameter is different) 2. Multimode fiber appear very light shadows after splicing 	<ol style="list-style-type: none"> 1. use the same type fiber on left and right side 2. it's normal, will not influence the fusion quality.
Fiber in screen is dislocation	<ol style="list-style-type: none"> 1. Fiber not enter the V-groove completely 2. V-groove is dirt 	<ol style="list-style-type: none"> 1. Re-place the fiber 2. Clean the V-groove with alcohol and brushes
The image is on the top or bottom of the display	<ol style="list-style-type: none"> 1. V-groove is dirt 2. Fiber not enter the V-groove 	<ol style="list-style-type: none"> 1. Clean the V-groove with alcohol and brushes 2. Re-place the fiber
The image is blurred	<ol style="list-style-type: none"> 1. Fiber not enter the V-groove 2. V-groove is dirt 	<ol style="list-style-type: none"> 1. Re-place the fiber 2. Clean the V-groove
Cleave can not cut off the fiber	<ol style="list-style-type: none"> 1. Cladding layer is not stripped 2. Cladding layer stripped too short and the rubber pressure on both sides of the blade did not compress the fiber 3. The cutting point of the blade becomes blunt or broken 	<ol style="list-style-type: none"> 1. Use a Miller clamp to peel off the cladding 2. The length of the stripped cladding should be longer than 30 mm 3. Loosen the retaining screw in the middle of the blade and turn the blade at an angle

VI: when you use the machine, normally it may happened the below problem:

Fiber Splicer is precision machine, when you daily use the machine, please avoid the dirt get into the machine, and keep daily clean of the machine.

1. Fiber has put on the V-grooves, but the machine prompt icon shows you that fiber is not on the V-grooves



1) fiber holder is not in the initial position, press the reset button  (the left first one), then put the fiber again on the v-grooves.

2)when you put the jumper fiber on the fiber holder, the white jacket is not hold by the fiber holder, the fiber holder front end need to press the white jacket.



2. fiber is put in the right way on the V-grooves and fiber end face is good position to the electrode tips. but machine still remind you the fiber put too long.

1)check the display is there dirt display in the screen page. if have then we need to clean the outside lens which is below the electrode. if the display still show the dirt on the screen, then please contact after sales service.

2)when the lens is fog also will happened this, then we need to clean the outside lens which is under the electrode, and you can use the hair dryer to blow the lens to remove the fog.

3. fiber has aligned but it didn't process the fiber fusion. It remind you to press the start button(the left second one) to continue the fiber fusion process.

1)if the screen show you the fiber end face error icon, then you need to re-cleave the fiber again.

2)If the screen didn't show any error icon, then check the function of the "Splice process pause". turn off it, it will auto process fiber fusion again.

[APP Page: Fiber Splicing Set->Function Configuration->Splice process pause]

4. focus failure

1)clean the outside lens which is under the electrode. Clean the V-grooves. Then press the reset button(the left first one).

2)Do machine self-checking, check that is there any error of the "focusing motor" error.

5.machine show you error icon:

Left and right side fiber is different types fiber, need to change to same type fiber to do the fiber fusion process.

Also if you thought that doesn't matter and your project can permit the different type fiber, then you can press the start button (the left second one)to continue the fiber fusion.

6.fiber is blur in same screen(X or Y screen)

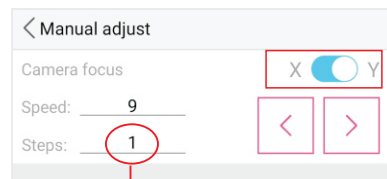
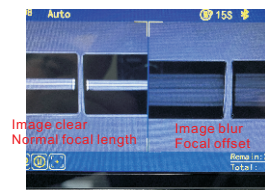

Slide to which side then adjust which side. now it stays at y side, so we adjust Y

Left and right control: can adjust the focus

If the value is big,it will be more obvious when you adjust the focus

Method:

- ① get into app and connect the machine, turn on the function auto focus [Fiber Splicing Set->Function Configuration->auto focus], save it. And then open the wind cover and close it, check the machine can it make the fiber show clear.
- ② If above can not solve it, then we turn off the auto focus, get into the page of the manual adjust[Fiber Splicing Set->Manual adjust], like the picture show you.
- ③ Do machine self-checking, check that is there any error of the "focusing motor" error.

7.Fiber all show in the screen but one side fiber is dislocation, X or Y screen one of them show the fiber blur.

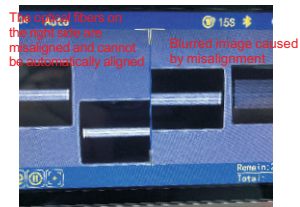

Method:
 1) clean the V-grooves, then press the reset button (the left first one)
 2) manual adjust the fiber dislocation, like the pictures show
 [Fiber Splicing Set->Manual adjust]

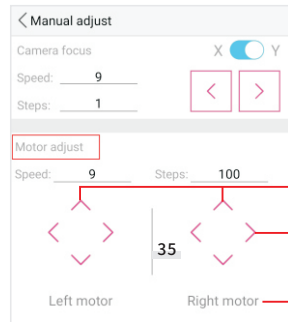

up and down button, to control the fiber move up and down in the screen
 left and right button, to control the fiber move left and right in the screen
 left motor control left side fiber right motor control right side fiber

8. fiber fusion quality is high loss

There are many reasons will make the High loss of the fiber fusion: machine status, machine discharge level, fiber end face quality, is the fiber clean, is the fiber's type same, fiber quality, and the fiber tension status.

Method to solve the high loss of the fiber fusion:

- 1) check that did the fiber fusion make the high loss. You can use a jumper fiber to do a test of the fusion loss: test the initial jumper fiber loss with OPM, then cut the jumper fiber and do a fiber fusion on it, then test again the loss of the fiber fusion. If the loss change too much, then we do the follow steps to check the fusion problem.
- 2) clean the V-grooves, clean the outside lens which is below the electrode, clean the electrode tips. After you have done the clean job, then we do an arc calibration until the machine remind you the arc calibration is succeed.
- 3) Pay attention to the fiber clean: after removing the fiber cladding, please clean with alcohol cotton, then cleave the fiber end face good (no burr and flat end surface), when you put the fiber on the V-grooves, fiber end face please don't contact the V-grooves.

- 4) Left and right side fiber, we recommend you to use the same type and specification fiber to do the fiber fusion.
- 5) Adjust the cleaver in good condition, so that we can low down the fiber end face influence.
- 6) Fiber fusion has done but the fiber will break in the near future and fusion has a high loss:
 - ① Please clean the V-grooves and the electrode tips, do an arc calibration until it reminds you the arc calibration is succeed.
 - ② Adjust the heating oven heating time
 If the heating time is short, the sleeve will slide and can not protect the fusion point.
 If the heating time is too long, will make the sleeve to extruded fiber then make the fiber hurt which we can not see.
 - ③ when you heat the protection sleeve after you have done the fiber fusion of Drop Cable Fiber, please use double steel wire protection sleeve.
 - ④ when you heat the protection sleeve, please don't tight the fiber too hard, take the fiber normally into the heating oven.

9 spliced fiber is easy broken

- 1) Broken from the fusion point, that means the arc-discharge is not suitable for the local environment, please clean the electrode tips, clean the outside lens which below the electrode, clean the V-grooves then do an arc calibration until it reminds you succeed.
- 2) if fiber broken from the fiber holder front pin. Then we need check that did the fiber holder front pin press the fiber where the cladding has removed. Make sure that fiber holder front pin should press the jumper fiber white sleeve, should press the bare optical fiber cladding.

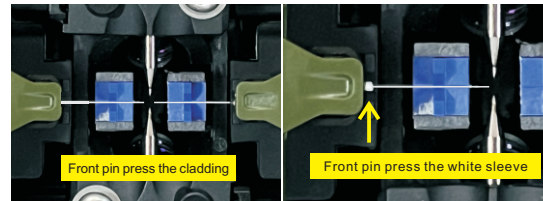

Daily Maintenance

Frequently remind you need to cleave the fiber again, remind you that machine can not recognize the fiber1)fiber end face is not good, please check the fiber cladding did it have been removed, remember to clean the fiber, and check the cleaver did it well work.

2)Fiber is blur and give you the error remind: like the fiber is dislocation, focus is blur.(Solution please check previous content)

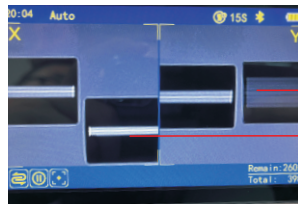
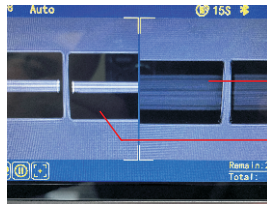

Image blurring caused by misalignment

There is a lot of fiber misalignment on the right side, which cannot automatically align the core



Focal offset Image blur

Normal focal length Clear image

3)Lens have fog and dirt on it, make the machine misleading the error. Or you can see one of the screen display is a little white.
Solution:wipe the lens or use hair dryer to blow dry.

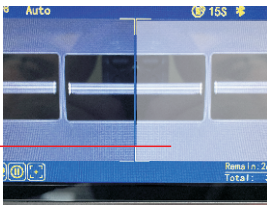

The fiber focus is same like Y side but the X screen shows more dark and blur